

ITEM: FIXED CAP END

MATERIAL: TYPE 316 STAINLESS STEEL.

FITTING TYPE: NON-ADJUSTABLE CABLE END FITTING

SWAGE TYPE: MACHINE HEX SWAGE AT FACTORY (1/8" & 3/16" SIZES ALSO AVAILABLE IN CABLECRIMP HAND SWAGE STYLE FOR ATTACHING IN THE FIELD).

POST TYPE: METAL. WOOD POSSIBLE IF CAP IS USED IN CONJUNCTION WITH A FLAT WASHER. (POSTS NOT INCLUDED).

FASTENING TO POST: ATTACH THROUGH END/TERMINATION POST HOLES USING A SCREW-ON END CAP.

FASTENING AT ANGLES: DRILL POST HOLES AT ANGLE AND USE BEVELED WASHERS.

CABLE TENSIONING: NON-ADJUSTABLE FIXED END.

HARDWARE PAIRINGS: USUALLY PAIRED WITH FIXED CAP END TURNBUCKLE. MUST BE PAIRED WITH A TENSION ADJUSTMENT FITTING, NOT ANOTHER FIXED END.

SUPPLIER: FEENEY ARCHITECTURAL PRODUCTS

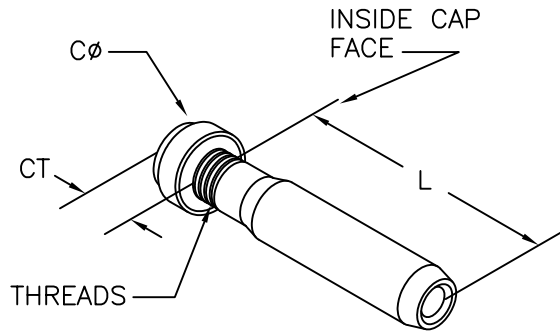

FIXED CAP END, STAINLESS STEEL

PART#	SWAGE TYPE	CABLE SIZE	THREAD SIZE	END CAP DIA (CØ)	END CAP THICK (CT)	LENGTH (L)	ATTACHMENT POST DRILL HOLE Ø
3315	MACHINE	1/8"	1/4-28RH	9/16"	5/16"	1-3/8"	5/16"
3316	MACHINE	3/16"	1/4-28RH	9/16"	5/16"	1-7/8"	3/8"
3317	MACHINE	1/4"	5/16-24RH	9/16"	5/16"	2-1/8"	7/16"
3318	CABLECRIMP	1/8"	1/4-28RH	9/16"	5/16"	2"	5/16"
3319	CABLECRIMP	3/16"	1/4-28RH	9/16"	5/16"	2-3/8"	3/8"

feeneyarchitectural
PRODUCTS

CableRail™-Custom Assemblies
2603 Union Street
Oakland, CA 94607-2423
Ph: 800-888-2418 or 510-893-9473
Fx: 510-893-9484, www.cablerail.com