

IN-LINE TURNBUCKLE - TYPICAL MID-SPAN, RAILING CONDITION  
(DETAILS TYPICAL FOR 1/8", 3/16" & 1/4" CABLE)

DWG # 187-ILTB DETAIL REV 2  
DATE 11/07

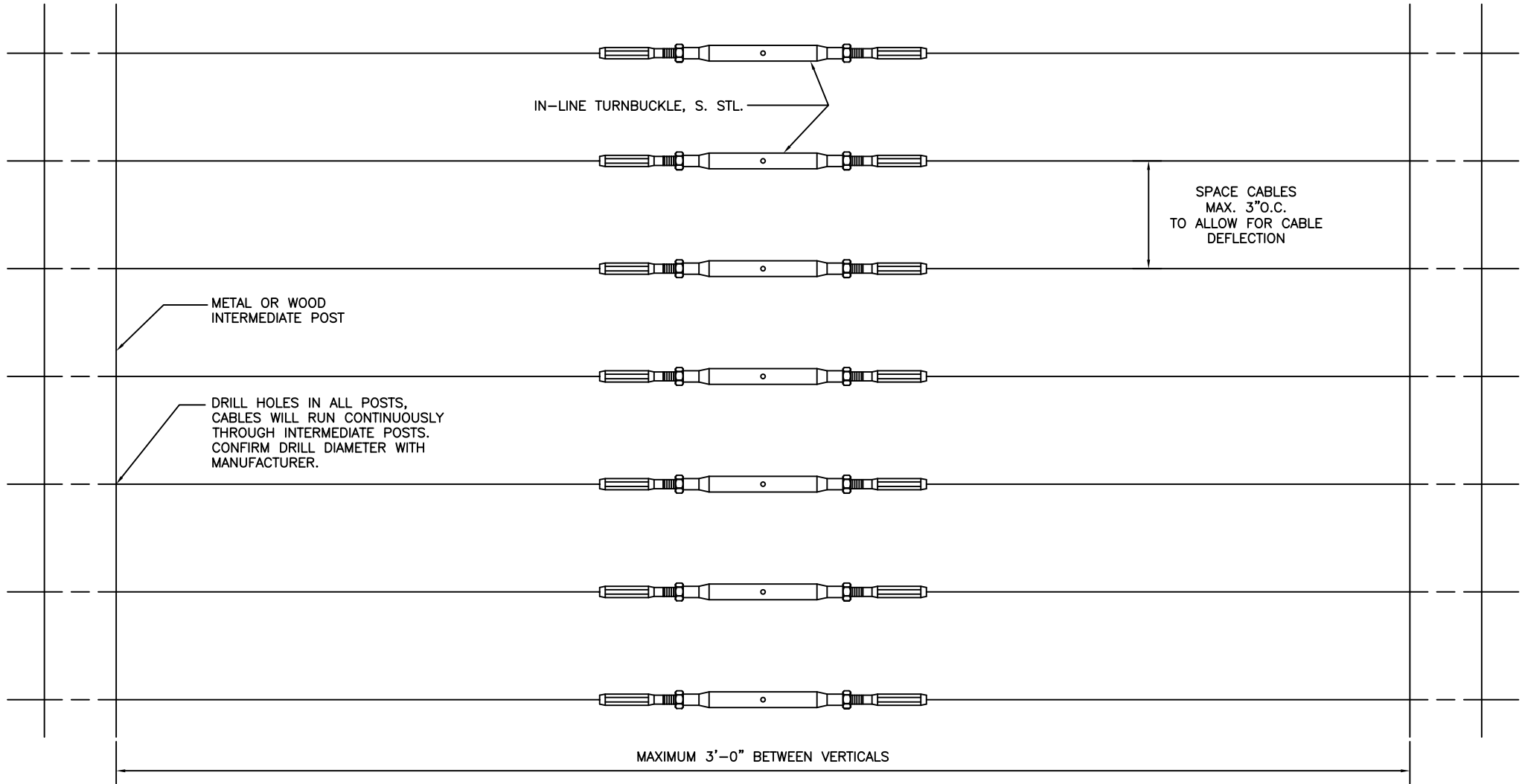

**feeneyarchitectural**  
PRODUCTS

CableRail™ - Custom Assemblies  
2603 Union Street  
Oakland, CA 94607-2423  
Ph: 800-888-2418 or 510-893-9473  
Fx: 510-893-9484, [www.cablerail.com](http://www.cablerail.com)