

QUICK-CONNECT-SS™: WOOD POST WITH ANGLED TERMINATION – STAIRS

NOTE: DETAIL IS TYPICAL FOR BOTH 1/8" AND 3/16"
DIAMETER STANDARD CABLERAIL™ ASSEMBLIES.

DWG # WD STAIR QCSS CAP REV 2
DATE 11/07

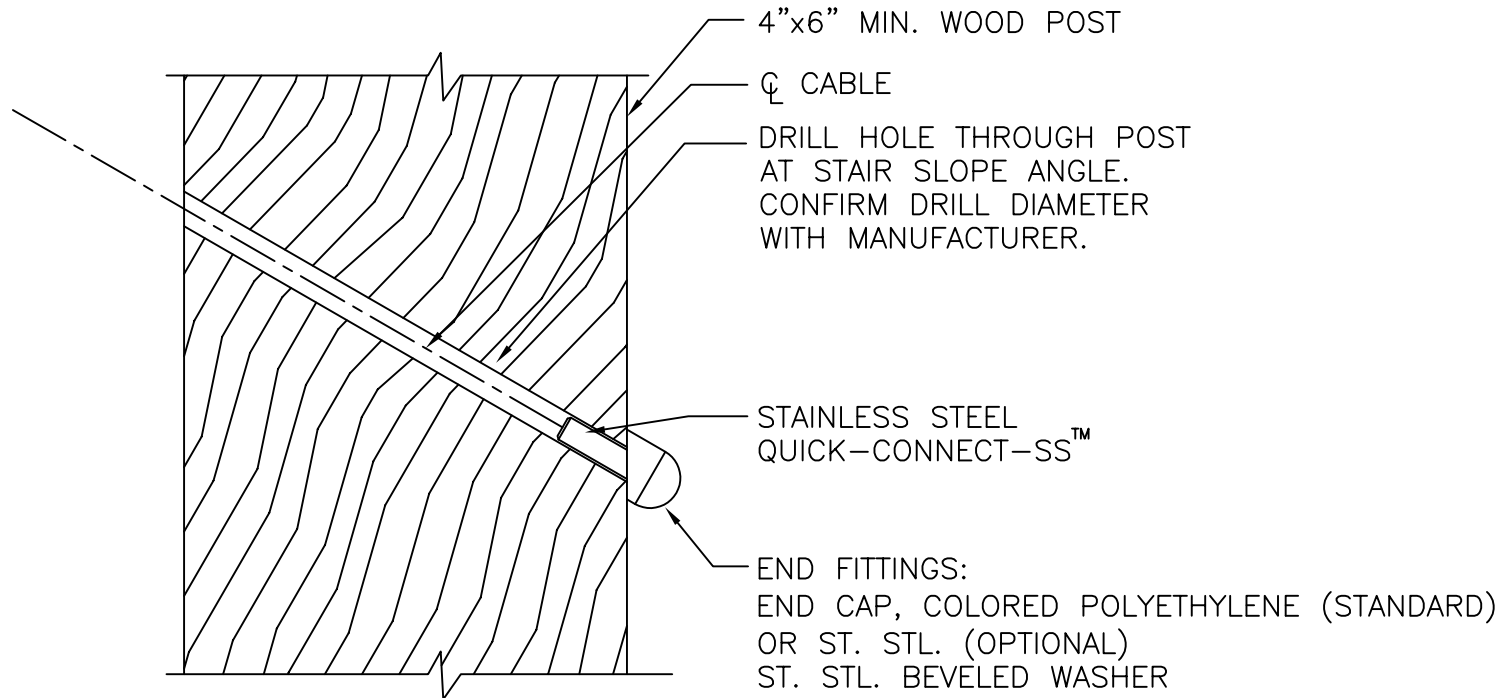

feeneyarchitectural
P R O D U C T S

CableRail™ – Standard Assemblies
2603 Union Street
Oakland, CA 94607-2423
Ph: 800-888-2418 or 510-893-9473
Fx: 510-893-9484, www.cablerail.com